

MS-A1004

Digital signal processing amplifier

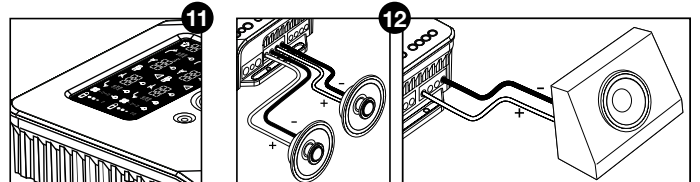

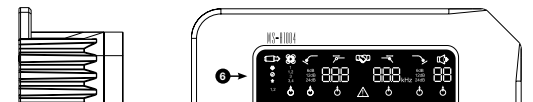
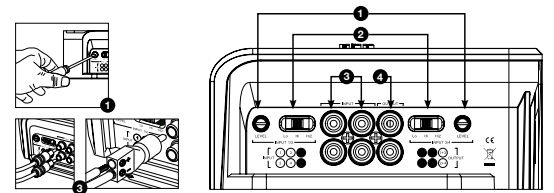
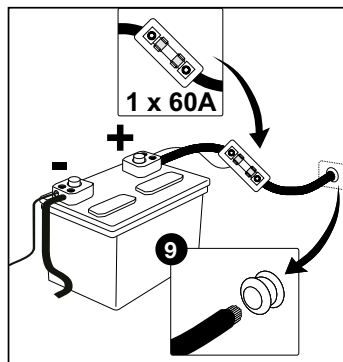
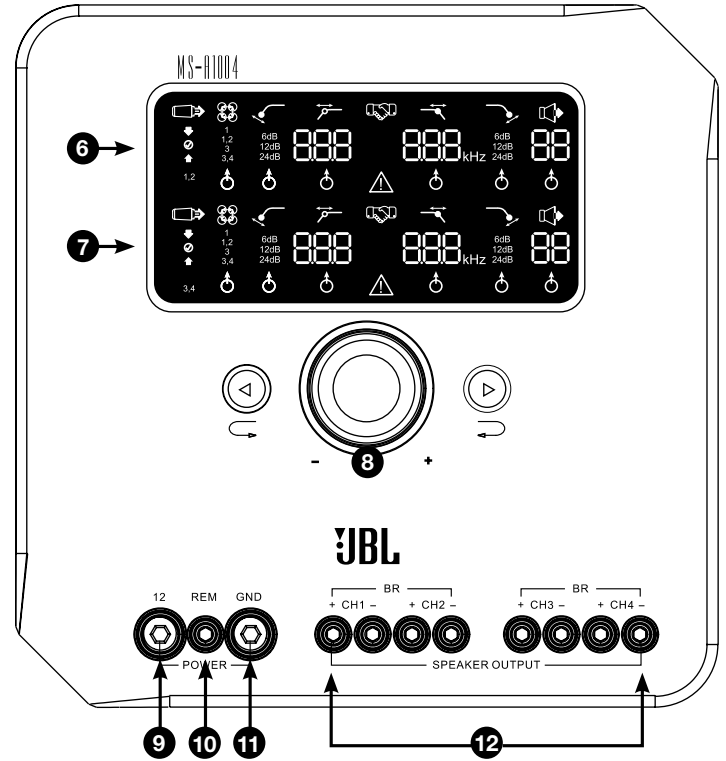
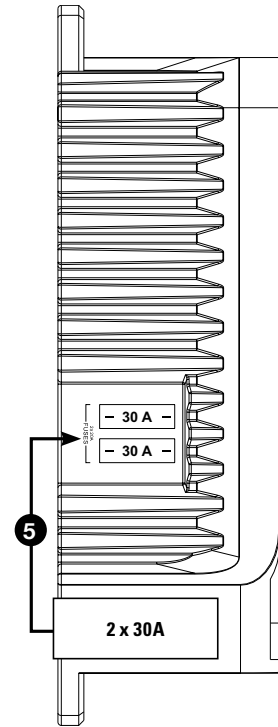
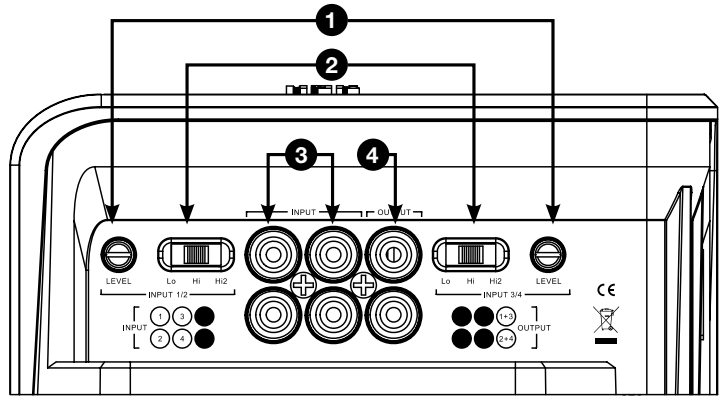
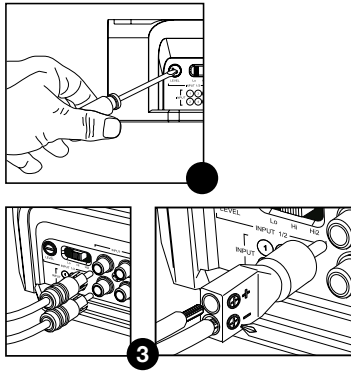

MS-A1004 FEATURES

1 Input-Level Control

Used to match the input sensitivity to the signal voltage for proper analog-to-digital conversion. See “Setting the Input Level, and Enabling or Disabling Signal-Sensing Turn-On” for details. DO NOT use these controls for setting the relative output level of amplifier channels!

2 Input Signal Selector

Lo/Hi/Hi2 sets the input voltage and impedance range. See “Setting the Input Level, and Enabling or Disabling Signal-Sensing Turn-On” and “The factory-installed system in my car shows a ‘speaker disconnected’ message, or it fails to play when a speaker is disconnected or when an amplifier is connected to its output. What should I do?” for details.

3 Audio Inputs

Use RCA audio cables for preamp-level connections or the included RCA-to-bare-wire adapters for speaker-level input connections.

4 Summed Pass-Through Outputs

Input channels 1 and 3 are combined and sent to one output. Inputs 2 and 4 are combined and sent to the other output.

5 Onboard Fuses

2 x 30A ATC type.

6 Channels 1 and 2 Display Panel

Displays the settings of channels 1 and 2 of the amplifier.

7 Channels 3 and 4 Display Panel

Displays the settings of channels 3 and 4 of the amplifier.

8 User Controls

Allows adjustment of amplifier settings. See “MS-A1004 User Controls” for details.

9 +12V Power Input

Connect to vehicle battery with a 60A fuse within 18 inches (45.7cm) of the positive battery terminal.

10 Remote Turn-On Input

Connect switched +5V to +12V. NOTE: The MS-A1004 also includes signal-sensing turn-on. You may choose the turn-on method during setup. See “How does the digital input mixer work?” and “MS-A1004 Connections” for details.

11 Chassis Ground Input

Connect to a paint-free spot on the vehicle chassis.

12 Speaker Outputs

MS-A1004

DIGITAL SIGNAL PROCESSING AMPLIFIER

PLEASE READ THIS BEFORE YOU BEGIN!

JBL MS Series amplifiers include many features not found on conventional car audio amplifiers. Also, the setup procedure for MS Series amplifiers is different from that of conventional car audio amplifiers. The following overview of features and functions will help you plan a great system and make the best use of the MS-A1004’s innovative features.

About the digital signal processing (DSP) included in MS Series amplifiers:

All of the signal processing in MS Series amplifiers is digital. Digital signal processing, along with the intuitive controls and display included in MS Series amplifiers, makes precise setup easy. Only the input-level controls are analog.

Will my settings be lost if I disconnect the amplifier or the car’s battery?

No. All of the DSP settings are stored in nonvolatile memory, so no settings will be lost if power is removed from the amplifier.

Why are the input-level controls analog?

In order to provide the best signal-to-noise ratio and to maximize the resolution of the digital-to-analog conversion, the maximum input signal level to the analog-to-digital (A/D) converters must be precisely set. This must be an analog control. The included setup CD and the procedure described in this manual make setting the level simple and precise. Once the input-level control is set, the control should not be used to “tune” the system. Use the digital output-level control to adjust the relative level between amplifier channels to tune the system.

FCC REGULATIONS

FCC INFORMATION FOR USERS

This device complies with Part 15 of the FCC Rules. Operation is subject to the following two conditions: (1) This device may not cause harmful interference; and (2) this device must accept any interference received, including interference that may cause undesired operation.

RADIO AND TELEVISION INTERFERENCE

This equipment has been tested and found to comply with the limits for a Class B digital device, pursuant to Part 15 of the FCC Rules. These limits are designed to provide reasonable protection against harmful interference in a residential installation. This equipment generates, uses and can radiate radio frequency energy and, if not installed and used in accordance with the instructions, may cause harmful interference to radio communications. However, there is no guarantee that interference will not occur in a particular installation. If this equipment does not cause interference to radio or television reception, which can be determined by turning the equipment off and then on, the user is encouraged to try to correct the interference by one or more of the following measures:

- Increase the separation between the equipment and receiver.
- Connect the equipment to a different outlet so that the equipment and receiver are on different branch circuits.
- Consult the dealer or an experienced radio/TV technician for help. Changes or modifications not expressly approved by JBL could void the user’s authority to operate the equipment.

IC STATEMENT AND WARNING

This Class B digital apparatus complies with Canadian ICES-003. Cet appareil numérique de la classe B est conforme à la norme NMB-003 du Canada.

IMPORTANT NOTE FOR ALL ELECTRONIC PRODUCTS:

Before inserting or unplugging audio cables from the source device’s headphones or line-level output jacks, it is good practice to turn off the device first. This will prolong the life of your unit, help protect your device from static electricity and prevent potential damage.

Why are the signal inputs and speaker outputs numbered rather than labeled “left” and “right”?

MS Series amplifiers are designed to make integration into any system simple and straightforward. The amplifier includes a digital input-mixer control, which eliminates the need for Y adapters and allows any pair of output channels to be driven by a mono or stereo signal for maximum system-building flexibility. Labeling the channels “left” and “right” would be confusing in some applications.

How does the digital input mixer work?

The signals from each of the RCA-type input connectors are converted into digital signals and sent to the digital signal processor. Inside the DSP, those signals are routed to the speaker output pairs, according to the selections in the input mixers. There’s one input mixer for output channels 1 and 2 (upper display) and another mixer for channels 3 and 4 (lower display). For example, selecting “1” in the input mixer for channels 1 and 2 will send only the signal connected to Input Jack 1 to output channels 1 and 2 (see Figure 1). This is useful for sending a mono signal to a pair of channels.

Figure 1.

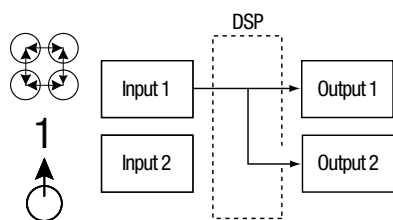

Selecting “1, 2” in the input mixer for channels 1 and 2 will send the signal that is connected to Input Jack 1 to Output 1 and the signal connected to Input Jack 2 to Output 2 (see Figure 2). This is designed for stereo signals.

Figure 2.

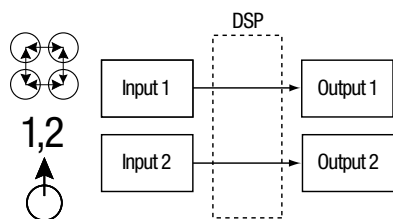

If you want all four output channels to receive the same signal, connect that signal to Input Jack 1 (or 3) and select “1” (or “3”) in both input mixers. If you want all four channels to receive separate signals, choose “1, 2” in one input mixer and “3, 4” in the other. Many system configurations are possible and Y adapters are never needed. See “System Diagrams” for more examples.

Does the amplifier include speaker-level and line-level inputs?

Yes, any input signal can be used with MS Series amplifiers. If your head unit includes RCA-type outputs, simply plug them into the RCA-type input jacks. If your head unit does not include RCA-type outputs (as is the case with all factory-installed systems), use the included RCA-to-bare-wire adapters. Be sure to observe proper polarity. The signal inputs are differential and will accept any signal from 100mV (low-level) to 15V (high-level). There’s no need to use separate adapters or to precisely determine the signal voltage or type. MS Series amplifiers’ onboard tools and the setup procedure described later in this manual will make optimizing the configuration simple.

The factory-installed system in my car shows a **speaker disconnected** message, or it fails to play when a speaker is disconnected or when an amplifier is connected to its output. What should I do?

MS Series amplifiers include three Input Signal Selector positions: Lo, Hi and Hi2. The Hi2 position includes a circuit designed to fool the factory system into “seeing” a speaker connected to its output. If your car has one of these systems, set the Input Signal Selector to Hi2 and follow the rest of the setup instructions.

My factory-installed head unit does not include a remote-turn-on wire. What should I do?

MS Series amplifiers include signal-sensing turn-on. A remote-turn-on connection is never required. The amplifier will sense the presence of an audio signal at its inputs and turn on automatically. A few minutes after the signal stops or after the radio is turned off, the amplifier automatically will turn itself off. During the delay, the amplifier draws very little current so the vehicle’s battery won’t be drained.

What is the best procedure for choosing a crossover frequency and slope (see Figures 3a and 3b)?

A crossover is a pair of filters that divide the audio signal into low frequencies (bass) and high frequencies (treble) so that only the appropriate signals are sent to speakers that are designed to reproduce a limited range. For example, a tweeter is designed to play only high frequencies, and too much bass can cause damage. A woofer is designed to make only low frequencies and does a poor job of reproducing high frequencies. A midrange speaker is designed to play frequencies in between bass and treble (midrange frequencies). Figure 3a shows how these speakers would be divided up across the 20Hz – 20kHz range, using the appropriate filters (crossovers).

Figure 3a.

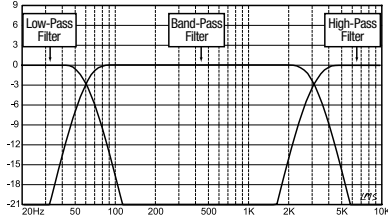
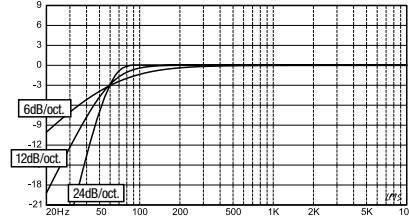

Figure 3b.



When setting a crossover between a low-frequency speaker and a high-frequency speaker, the high-pass filter (HPF) frequency should be chosen to keep the high-frequency speaker safe. The low-pass filter (LPF) should be set so that the hand-off provides smooth response in the region near the crossover frequency. When implementing a crossover between speakers, use steep (24dB/octave) slopes for both filters to maximize the amount of low frequencies that the high-frequency speaker can handle safely and to minimize the interaction of the sound between the low-frequency speaker and the high-frequency speaker. Figure 3b shows the differences of 6dB, 12dB and 24dB/octave filter slopes.

If I should use 24dB/octave slopes for crossovers, why do MS Series amplifiers include 6dB and 12dB/octave slopes too?

If your MS Series amplifier will be used to power a subwoofer in a vented (ported) box, use a 12dB/octave high-pass filter to protect the subwoofer from damage by limiting the amount of bass that's sent to the subwoofer below the tuned frequency of the box. A 6dB/octave high-pass filter can be useful in slightly limiting the amount of bass sent to full-range speakers in systems where no subwoofer will be used, limiting the amount of high frequencies sent to rear speakers.

Why does each pair of channels include a high-pass filter (HPF) and a low-pass filter (LPF)?

In some systems, it can be useful to limit the high frequencies and low frequencies that are sent to a loudspeaker. Use the HPF and the LPF together to create a band-pass filter for a midrange speaker in systems where the woofer, midrange and tweeters will be powered by individual amplifier channels. When using the filters to create a band-pass filter, the HPF can never be set to a higher frequency than the LPF. For example, if the LPF is set to 200Hz, the HPF can be set to any frequency below 190Hz. This protection prevents errors in setup.

Do MS Series amplifiers include a subsonic or infrasonic filter for use with vented enclosures?

Yes. If you want to use a subsonic or infrasonic filter with your subwoofer, configure the channel's crossover as a band-pass filter. The low-pass filter will limit the high frequencies that are sent to the subwoofer and the high-pass filter will be the infrasonic filter. Set the high-pass filter frequency about 10Hz below the frequency at which the enclosure is tuned and use a 12dB/octave slope (see Figure 4).

Figure 4.

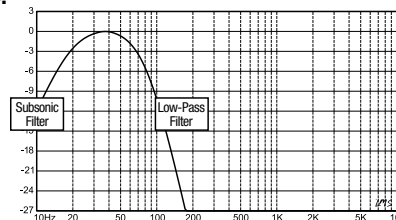

About the MS-WBC wireless bass control (sold separately):

The MS-WBC wireless bass control is designed to make installation easy. The circuit is designed for long battery life, and a separate, wired connection to +12V is included for those who never want to replace the battery. No wired connection to the amplifier is necessary. The control sends a radio signal to the DSP in the amplifier, so the control may be mounted in a console or under the dashboard and the amplifier may be mounted in the trunk or hidden behind a panel.

The amount of bass included in recordings varies greatly, and the ability to adjust the amount of bass between songs or albums is useful. Unlike conventional remote bass controls, the MS-WBC doesn't simply increase the level of the amplifier's channels that are connected to the subwoofer. Conventional bass controls adversely affect the crossover between the subwoofer and the mid-bass or midrange speakers any time they are adjusted. This causes the bass to sound boomy or muddy when it's boosted and draws the listener's attention to the location of the subwoofer (see Figure 5a).

Figure 5a.

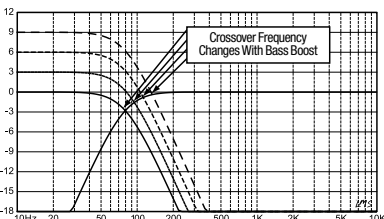
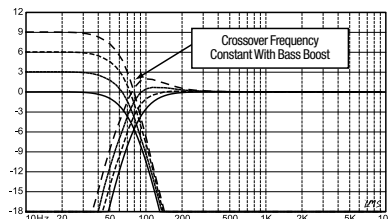

Figure 5b.



The bass-boost filter in the MS Series amplifiers is a shelf filter that boosts or cuts bass below 60Hz, but never above 160Hz. The range of adjustment is ± 10 dB. Additionally, the bass boost or cut is sent to all the amplifiers with which the control is paired. The bass control works with the crossover filters to ensure that the proper amount of boost or cut is sent to the subwoofer and the mid-bass or midrange speakers, so the character and apparent location of bass sounds remain constant. See Figure 5b for the performance of the MS-WBC (as opposed to that of conventional bass controls, as shown in Figure 5a).

CAUTION: Installation of car audio components requires experience in performing mechanical and electrical procedures. If you feel you lack the required experience or necessary tools, please have your amplifier installed by a qualified professional technician.

CAUTION: Before installation, disconnect the negative (-) battery terminal to prevent the battery from being drained while you work on the car and also to prevent damage to the unit.

READ THIS BEFORE STARTING INSTALLATION!

1. JBL MS Series amplifiers include many features not found on conventional car audio amplifiers. The setup procedure for MS Series amplifiers is different from that of conventional car audio amplifiers. Be sure to carefully read and understand these instructions before attempting installation.
2. At the installation sites, locate and make a note of all fuel lines, hydraulic brake lines, vacuum lines and electrical wiring. Use extreme caution when cutting or drilling in and around these areas.
3. Choose a mounting location for the amplifier inside the passenger or cargo area that will ensure no exposure to moisture. Never mount an amplifier outside the car or in the engine compartment.
4. Make sure there is sufficient air circulation at the mounting location for the amplifier to cool itself.
5. Mount the amplifier securely.

MS-A1004 CONNECTIONS

Power Inputs

1. +12V Power Input

Connect the unit to the vehicle battery using a minimum size of 8 AWG (8mm²) wire with a 60A fuse placed within 18 inches (45.7cm) of the positive battery terminal. Be sure to use an insulation grommet at every location where the power wire will pass through metal.

2. Remote Turn-On Input (Optional to Connect)

No discrete remote-turn-on connection to the MS-A1004 is necessary. If your head unit includes a remote-turn-on lead and you wish to connect it, connect the unit to this terminal.

3. Chassis Ground Input

Using at least 8 AWG (8mm²) wire, connect this terminal to a nearby point of the vehicle's chassis (sheet metal). Scrape away the paint from the area to ensure a good connection. Do not ground the amplifier to the vehicle's frame.

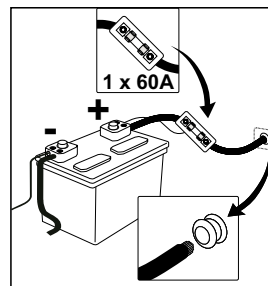

Audio Inputs

1. Using RCA Outputs

If the unit that precedes this amplifier in the signal chain includes RCA-type output connectors, connect them directly to the RCA inputs of this amplifier.

2. Using Speaker-Level Signals

If the preceding equipment doesn't have RCA-type connectors, use the RCA-to-bare-wire adapters included with the MS-A1004. Connect the + signal to the terminal marked + and the - signal to the terminal marked -.

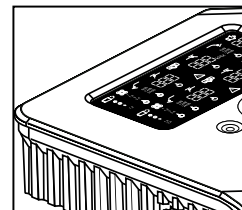

Pass-Through Audio Outputs (Full-Range)

Input channels 1 and 3 are summed and sent to the top RCA output. Inputs 2 and 4 are summed and sent to the bottom RCA output. Using these outputs, additional amplifiers can be easily added. For example: When using the MS-A1004 for front and rear speakers, you could use these outputs for a subwoofer amplifier. The outputs are full-range. No high-pass or low-pass filters are applied in the MS-A1004.

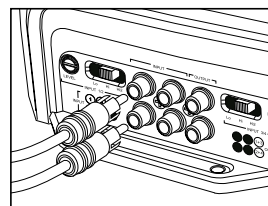

Speaker Outputs

Connect each speaker to the amplifier channel that will correspond to the input used or how it's assigned. See "Setting the Input Mixer" to learn how to assign the input signals to the output channel pair. Be sure to observe proper polarity when connecting the speakers to the outputs.

1. Stereo Connection

Connect the left-channel loudspeaker(s) to the output terminals corresponding to the left-channel input. Connect the right-channel speaker(s) to the output terminals corresponding to the right-channel input.

2. Bridged Connection

Connect the positive terminal on the loudspeaker(s) to the positive (+) terminal on Channel 1 (or 3). Connect the negative terminal on the speaker(s) to the negative (-) terminal on Channel 2 (or 4).

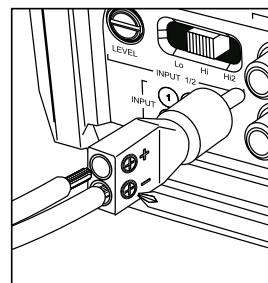

See "System Diagrams" for examples of system configurations in which the amplifier is most commonly used.

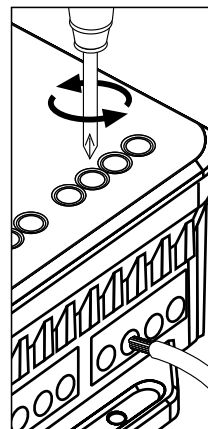

MS-A1004 DISPLAY ICONS

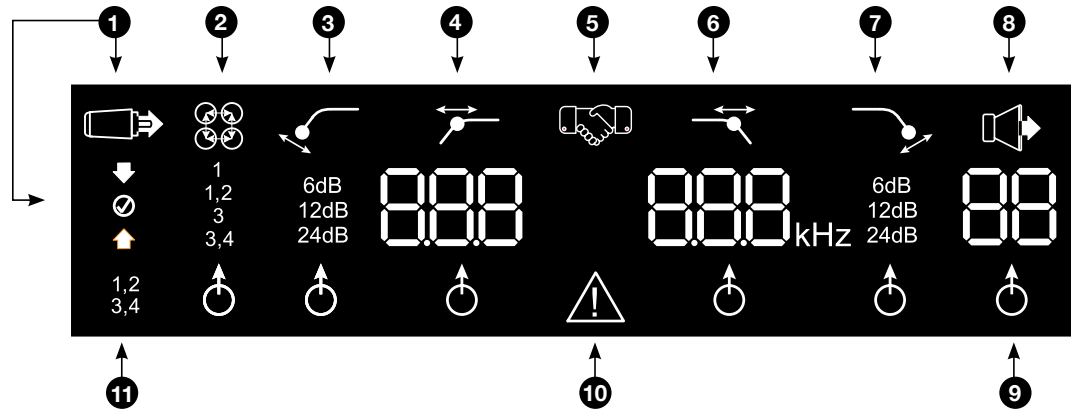

1 Input-Level Settings

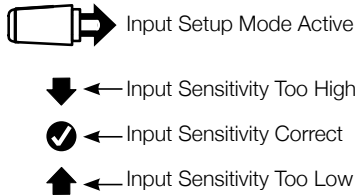

2 Input Channel Mixer

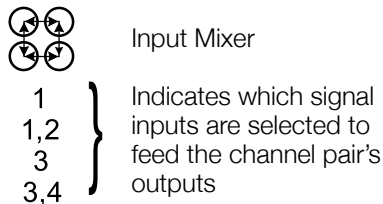

High-Pass Filter

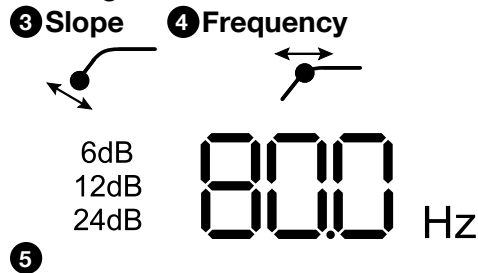

5

Pairing Confirmation



*The MS-WBC wireless bass controller is an optional accessory.

Low-Pass Filter

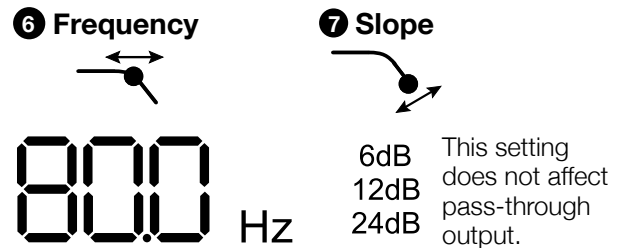

8 Output Gain Adjustment

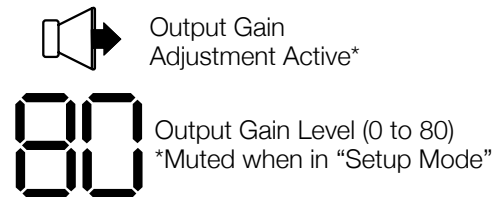

9 Adjustment-Selection Indicator

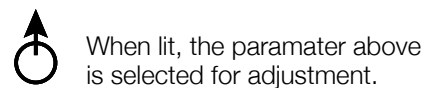

10 Protection



11 Channel ID

1,2 Indicates the amplifier channels affected by the row of settings to the right in the display. (Channels 1, 2 use the upper display and channels 3, 4 use the lower display.)

3,4

MS-A1004 USER CONTROLS

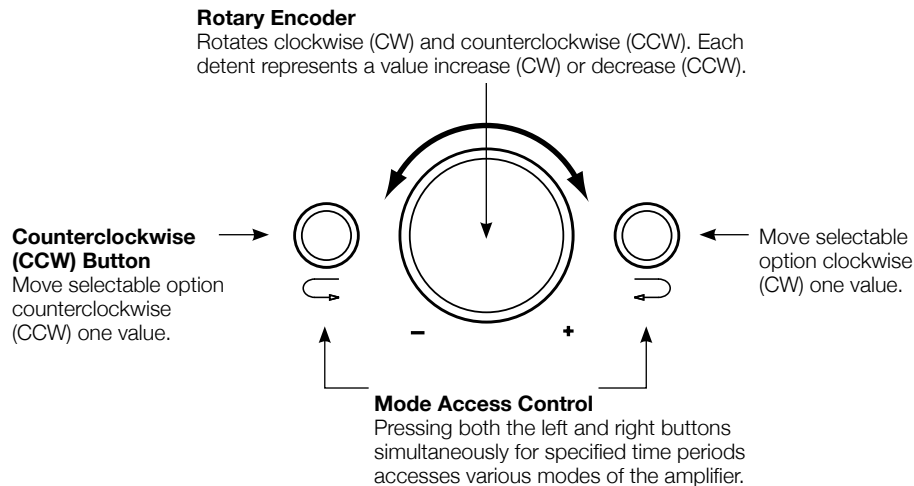

MS-A1004 SETTINGS GUIDE

INITIAL SETUP

Activating the Controls

Press both CCW and CW buttons at the same time for less than three seconds and release, to activate the controls. The adjustment selector indicator will light. Use the CCW and CW buttons to move the indicator to the parameter you wish to adjust. After you've made your adjustments and the controls have been inactive for more than 30 seconds, the selection-indicator light will go out and the controls will become deactivated to prevent unintentional adjustment of the amplifier's controls.

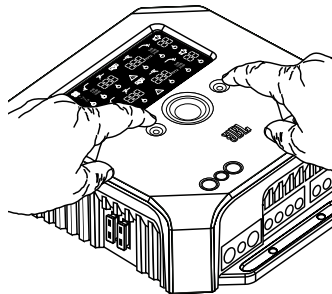

Setting the Input Mixer



- 1
- 1,2
- 3
- 3,4

Once the controls are active, press the CW or CCW button until the input mixer is selected for channels 1 and 2 (in the upper display) . Turn the rotary control to select the input connector(s) that will feed output channels 1 and 2. Press the CCW button once to move the selection indicator to the input mixer for channels 3 and 4 (in the lower display). Turn the rotary controller to select the input connector(s) that will feed output channels 3 and 4.

See "System Diagrams" for practical examples.



Setting the Input Level, and Enabling or Disabling Signal-Sensing Turn-On BEFORE YOU BEGIN

If the factory system to which you have connected your MS Series amplifier shows a "speaker disconnected" error message or fails to provide an output signal, move the Input Signal Selector to the Hi2 position. It may be necessary to turn the factory-installed head unit or the vehicle itself off and then back on, to reset the error message.

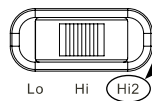



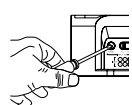

NOTE: The Hi2 setting should not be used with the RCA outputs of aftermarket head units!

 **To Set the Input Level:**

1. Move the switch for the Input Signal Selector to the Hi position (or Hi2, if you are connecting to a factory system with open-circuit protection).
2. Set the bass, treble, balance and fader controls on your head unit to the center (or flat) positions. Set loudness to off. Defeat any sound-enhancement (such as DSP, surround sound or EQ) settings.
3. Insert the setup CD into your head unit and verify that the CD is playing.
4. Enter Setup mode by pressing CW and CCW buttons simultaneously for more than three seconds until the Input Level adjustment icon  lights. The amplifier's output will be muted (the output-level indicator will show "■■■■" in the display).
5. Turn the head unit's volume control all the way up (to maximum output).
6. Using a small screwdriver on the level-adjustment dial next to the Input Signal Selector switch, adjust the Input-Level Control up or down, while watching the icons on the amplifier's display panel.



- If the green "up" arrow  icon is lit, turn the control clockwise until the  icon is lit.
- If the red "down" arrow  icon is lit, turn the control counterclockwise until the  icon is lit.



NOTE: If turning the control fully clockwise doesn't cause the  icon to light, move the switch for the Input Signal Selector to the Lo position and try again.

Once the  icon is lit, stop adjusting and repeat the procedure to set the input level on the other channels. When both check marks are lit, the input levels for each channel pair are set properly.

To Enable or Disable Signal-Sensing Turn-On:

7. While in Setup mode, enable/disable signal-sensing turn-on by turning the rotary controller clockwise or counterclockwise to select SEn On or SEn OFF in the display. If you have connected a remote turn-on lead, set to SEn OFF.
8. Turn the volume control on your head unit down and remove the setup CD. If you miss or circumvent this step, the audio system will reproduce a loud test signal that could damage speakers when exiting the Setup mode.
9. Press and release the CW and CCW buttons simultaneously to exit Setup mode.
10. Do not adjust the Input-Level Controls further. Use the Output Gain Control to balance the channel levels and to "tune" the system.

Mode	Function
SEn On	Signal Sensing is ON
SEn OFF	Signal Sensing is OFF



SETTING THE FILTERS (CROSSOVERS)

There are 98 selectable frequencies for the low-pass and high-pass filter settings. The selectable frequencies are detailed in the table to the right.

Getting to the Crossover Settings

Press both CCW and CW buttons at the same time for less than three seconds and release, to activate the controls. Use the CCW and CW buttons to navigate to the preferred crossover-adjustment parameter.

How to Set a High-Pass Filter



Navigate to the high-pass filter frequency parameter  and, using the rotary encoder, select the desired cutoff frequency. Then navigate to the high-pass filter slope parameter  and, using the rotary encoder, select the desired filter slope.

High-Pass Example

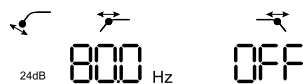
Use the CW and CCW buttons to navigate to the Low-Pass frequency parameter and set to OFF.



How to Set a Low-Pass Filter

Navigate to the Low-Pass Filter frequency parameter  and, using the rotary encoder, select the desired cutoff frequency. Then navigate to the Low-Pass Filter slope parameter  and, using the rotary encoder, select the desired filter slope.

Low-Pass Example

Use the CW and CCW buttons to navigate to the High-Pass frequency parameter and set to OFF.

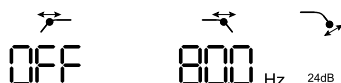

Available Crossover Frequency Settings				
20.0Hz	95.0Hz	260Hz	1.40kHz	4.80kHz
22.5Hz	100Hz	270Hz	1.50kHz	5.00kHz
25.0Hz	105Hz	280Hz	1.60kHz	5.50kHz
27.5Hz	110Hz	290Hz	1.70kHz	6.00kHz
30.0Hz	115Hz	300Hz	1.80kHz	6.50kHz
32.5Hz	120Hz	350Hz	1.90kHz	7.00kHz
35.0Hz	125Hz	400Hz	2.00kHz	7.50kHz
37.5Hz	130Hz	450Hz	2.20kHz	8.00kHz
40.0Hz	140Hz	500Hz	2.40kHz	8.50kHz
42.5Hz	150Hz	550Hz	2.60kHz	9.00kHz
45.0Hz	160Hz	600Hz	2.80kHz	9.50kHz
50.0Hz	170Hz	650Hz	3.00kHz	10.0kHz
55.0Hz	180Hz	700Hz	3.20kHz	12.0kHz
60.0Hz	190Hz	750Hz	3.40kHz	14.0kHz
65.0Hz	200Hz	800Hz	3.60kHz	16.0kHz
70.0Hz	210Hz	900 Hz	3.80kHz	18.0kHz
75.0Hz	220Hz	1.0kHz	4.00kHz	20.0kHz
80.0Hz	230Hz	1.10kHz	4.20kHz	OFF
85.0Hz	240Hz	1.20kHz	4.40kHz	
90.0Hz	250Hz	1.30kHz	4.60kHz	

How to Set a Band-Pass Filter

To build a proper band-pass filter, the low-pass frequency must be greater than the high-pass frequency. The MS-A1004 will not allow you to set the low-pass filter frequency to a lower value than the high-pass filter frequency. To enable a band-pass filter, first select the High-Pass Filter frequency and slope, as indicated above. Next, select the low-pass filter frequency and slope. Once the settings are complete, the controls will time out after 15 seconds.

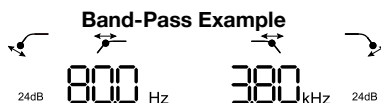

OUTPUT LEVELS

Setting the Output Level



Use the Output Gain Control to adjust the balance between the subwoofer and the full-range speakers, between the front and rear speakers, or between the midrange, mid-bass or tweeters in a bi-amped or tri-amped (all active) system. The output level is adjustable in 0.5dB increments, with a display of 80 indicating maximum output. The lowest setting will mute the output and “— —” will show in the display.

To set the output level, press the CW or CCW buttons to highlight the output-level parameter for adjustment, and turn the rotary controller to adjust the output level.

WIRELESS BASS CONTROL

Overview

The MS-WBC (sold separately) is battery-powered and also includes a +12V plug that can be connected to a +12V source in the vehicle. The MS-WBC transmits a signal only when the control is rotated. The amplifier(s) must be on to receive and respond to the control, so adjustments made to the control when the amplifier(s) is/are off aren't recognized.

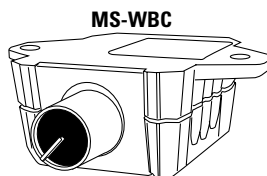

How to Pair the MS-WBC Wireless Bass Control with the MS-A1004

The optional MS-WBC wireless bass controller must be paired to the amplifier in order to be used. When the amplifier is first turned on, the amplifier is not paired with any controller.

Press and hold both CCW and CW buttons simultaneously for more than three seconds and the amplifier will enter Setup mode. Continue pressing the buttons for four more seconds until the pairing indicator  is illuminated. Release the CCW and CW buttons.

Pairing must occur within 15 seconds. The time remaining is indicated at the far right of the display. Turn the knob on the bass controller during this 15-second period. The wireless bass controller will be recognized by the amplifier and will automatically pair the two together.

After a successful pairing, the upper HP filter digits will display the bass controller version number for three seconds. Then the amplifier will return to the normal (RUN) mode.

If a valid pairing has not occurred, the amplifier will remain unpaired. After the 15-second countdown, the amplifier returns to the Setup mode.

If your system includes several MS Series amplifiers, pair them one at a time. Once all the amplifiers are paired and have returned to the normal (RUN) mode, turn the knob to synchronize all amplifiers.

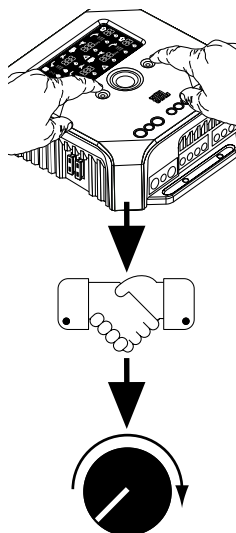

SYSTEM DIAGRAMS

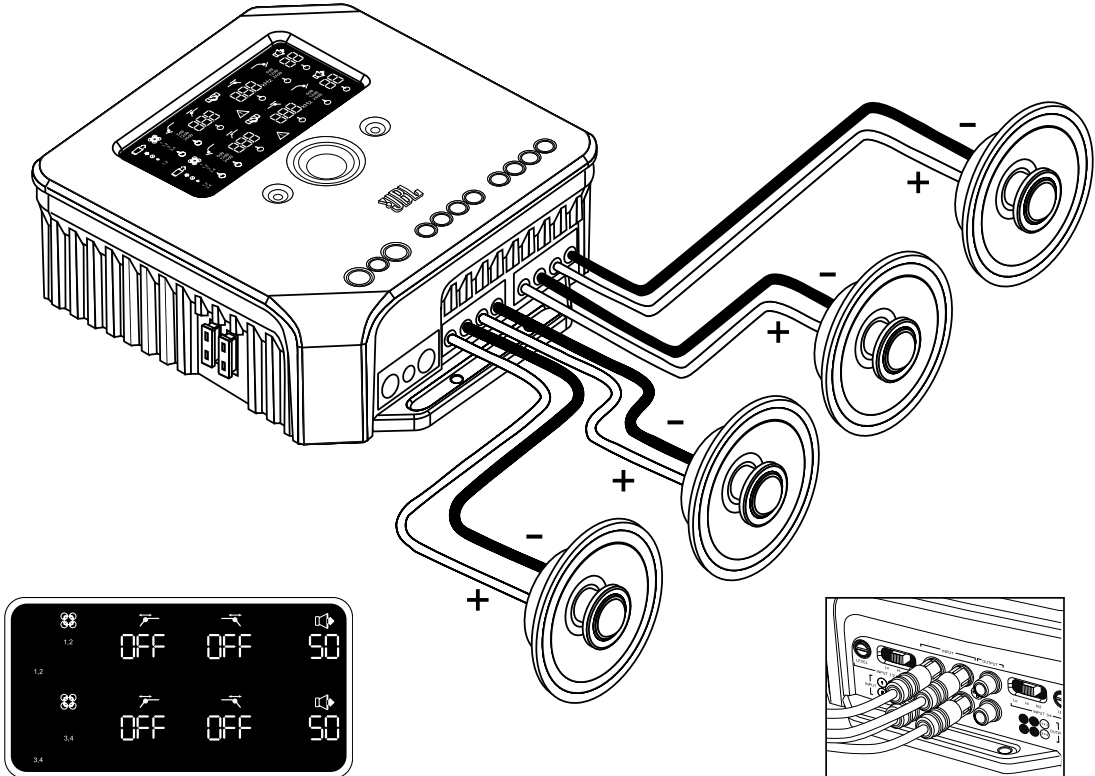

Example of filter and input settings for this configuration

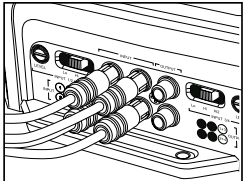

Inputs on all four channels

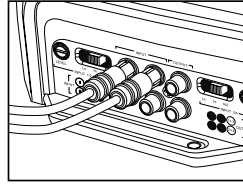
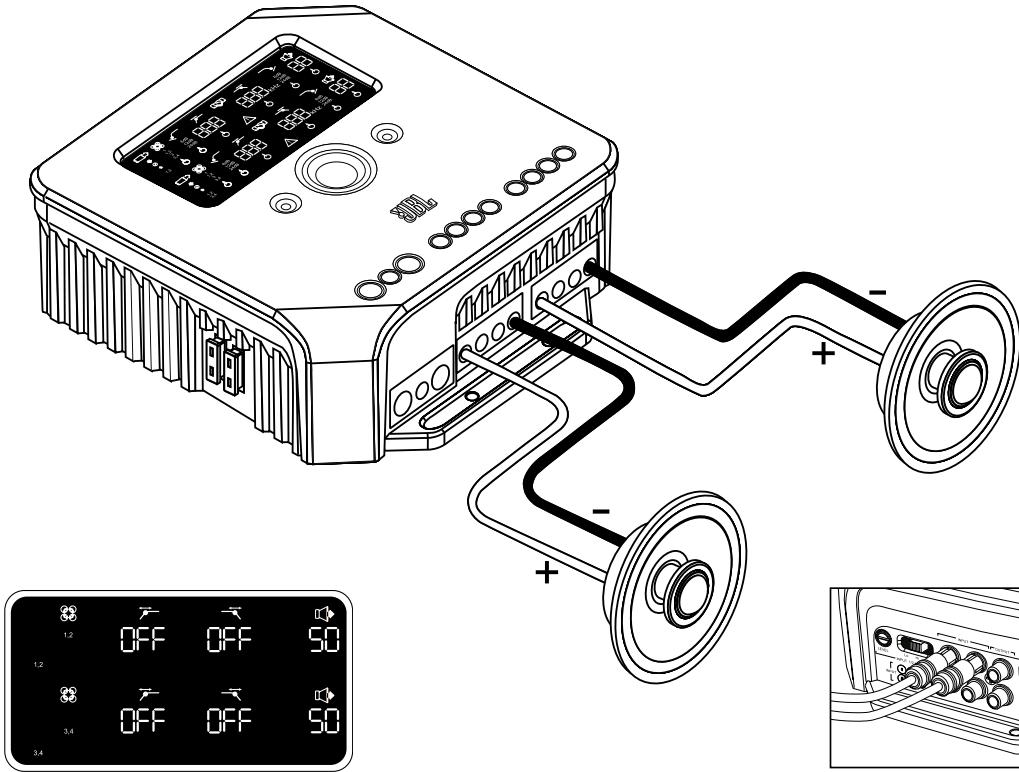

Inputs on channels 1 and 3

SYSTEM DIAGRAMS

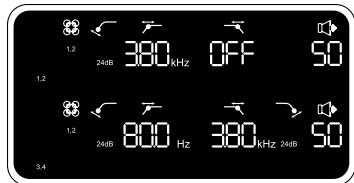
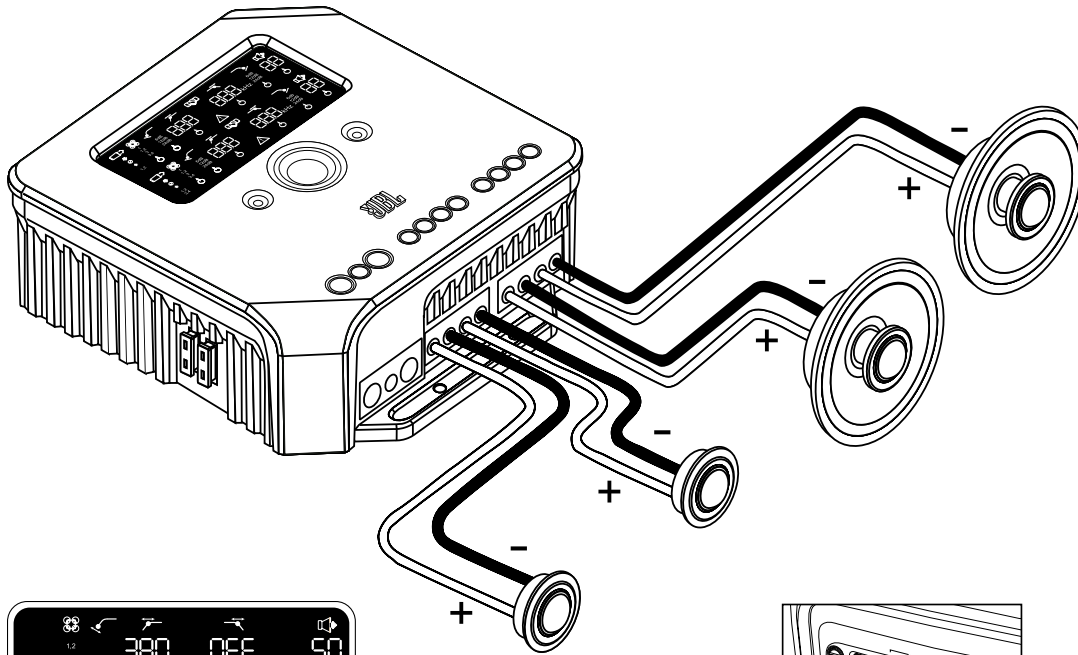

Example of filter and input settings for this configuration

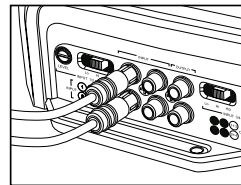

Inputs on channels 1 and 2

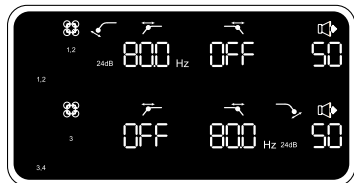
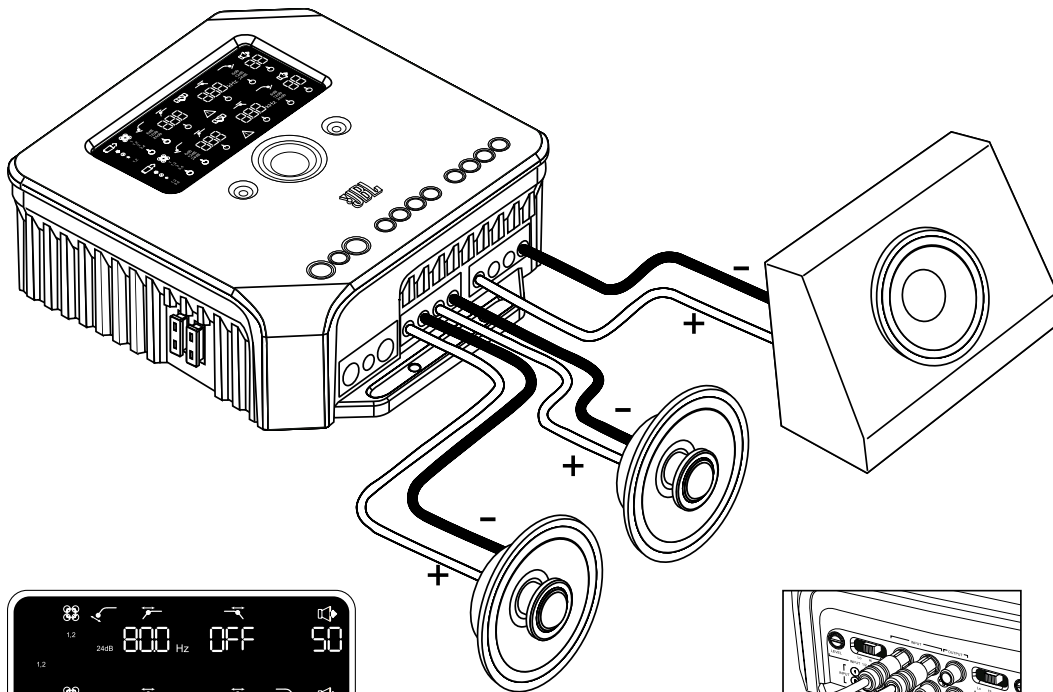

Example of filter and input settings for this configuration

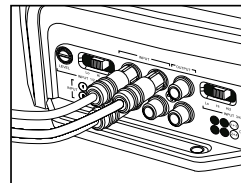

Inputs on channels 1, 2 and 3

SPECIFICATIONS

Specification	
Power output CEA 2006	100W RMS x 4 channels @ 4 ohms 100 W RMS x 4 channels @ 2 ohms 200 W RMS x 2 channels @ 2 ohms
Bridged mode	
Signal-to-noise ratio	80dB referenced to 1 watt 90dB referenced to rated power
Frequency response	10Hz – 27kHz (-3dB)
Maximum input sensitivity	100mV
Maximum input voltage	20V
Dimensions (L x W x H)	7-3/16" x 8-1/4" x 2-3/4" 183mm x 210mm x 70mm
Weight	5.57lb 2.53kg
Beauty carton dimensions	13-15/16" x 11-9/16" x 10-5/16" 354mm x 294mm x 264mm
Gross weight (with beauty carton)	14.61lb 6.63kg



© 2010 Harman International Industries, Incorporated. All rights reserved. JBL is a trademark of Harman International Industries, Incorporated, registered in the United States and/or other countries. CEA is a registered trademark of the Consumer Electronics Association. Features, specifications and appearance are subject to change without notice.

HARMAN

Harman Consumer, Inc.
8500 Balboa Boulevard
Northridge, CA 91329 USA

www.jbl.com